

CHECK OF OVERTEMPERATURE WITHIN BOARDS ACCORDING TO CEI 17-43 (HD 528 52) STANDARD

When creating boards not intended for domestic or similar use it is necessary to check the internal overtemperature with the method specified by the CEI 17-43 Standard based on the formula

$$D_{\vartheta 05} = kd W_d^{0.804}$$

where

- $D_{\vartheta 05}$ is the overtemperature at mid height.
- k is the coefficient of enclosure.
- d is a coefficient that takes into account internal horizontal obstacles hindering air circulation.
- W_d is the power dissipated by the components inserted in the board.

The coefficients k and d mainly depend on the dimensions, shape, type of installation and number of rows of modular devices.

Experimentally, GEWISS has obtained, for the 46 Range suitable for ANS type-boards, the overall coefficient \bar{k} (product kd) that simplifies the verification of overtemperature at mid height reducing it to the relationship

$$D_{\vartheta 05} = \bar{k} W_d^{0.804}$$

W_d is the power dissipated by the components inserted in the board. It can be calculated with the method described in point "B" of paragraph "CERTIFICATION CRITERIA FOR DISTRIBUTION BOARDS AND ENCLOSURES FOR DOMESTIC AND SIMILAR USE (CEI 23-51 STANDARD)" in the following pages. Raising to the exponent 0.804 is easy to obtain with a calculator equipped with exponential functions.

Coefficient \bar{k} and factor C of GEWISS boards

RANGE	CODE	\bar{k}	c
44 CEP	GW 44 808 GW 44 818	1.96	1.16
	GW 44 809 GW 44 819	1.99	1.22
	GW 44 810 GW 44 820	1.40	1.22
	GW 44 811 GW 44 821	1.11	1.21
46 QP	GW 46 001 GW 46 201	1.75	1.21
	GW 46 002 GW 46 202	1.29	1.23
	GW 46 003 GW 46 203	0.95	1.21
	GW 46 004 GW 46 204	0.81	1.24
	GW 46 005 GW 46 205	0.66	1.22
	GW 46 006 GW 46 206	0.50	1.35
	GW 46 007 GW 46 207	0.31	1.33
46 QM/QX	GW 46 031	1.75	1.21
	GW 46 032 GW 46 232 GW 46 052	1.29	1.23
	GW 46 033 GW 46 233	0.95	1.21
	GW 46 034 GW 46 234 GW 46 054	0.81	1.24
	GW 46 035 GW 46 235	0.66	1.22
	GW 46 036 GW 46 236 GW 46 056	0.50	1.35
	GW 46 037 GW 46 237	0.31	1.33

To determine maximum overtemperature $D_{\vartheta 1}$ (which for box boards with equivalent dispersion area up to 1.25 m² occurs in the upper part of the board as shown in the figure) multiply $D_{\vartheta 05}$ by factor "c" which is also predetermined by GEWISS.

Distribution of overtemperature

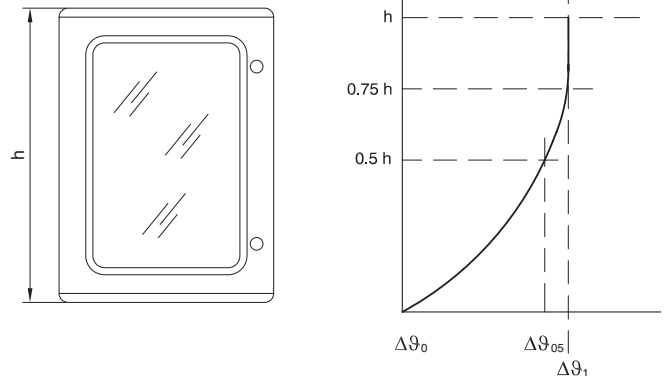

Example of use of total coefficient of enclosure \bar{k} and factor C specified for GEWISS 46 Range boards

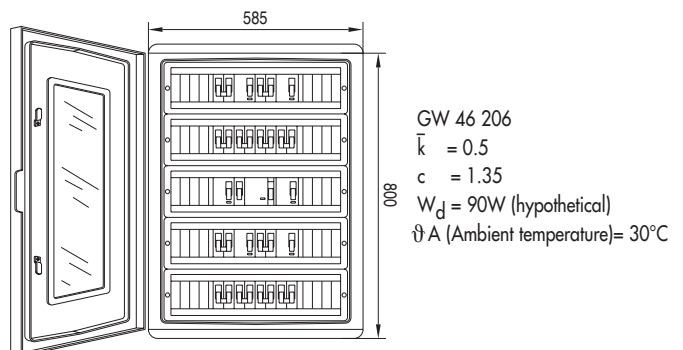

a) Obtain with calculator for $W_d = 90W \rightarrow W_d^{0.804} = 37.25 W$

- calculation of overtemperature at mid height:
 $D_{\vartheta 05} = 0.5 \times 37.25 = 18.62^\circ C$
- calculation of overtemperature at the top:
 $D_{\vartheta 1} = 18.62 \times 1.35 = 25.13^\circ C$

Temperature check

- for devices placed in the first row (above):
 $\vartheta_1 = \vartheta_A + D_{\vartheta 1} = 30 + 25.13 = 55.13^\circ C$
- for devices placed in the middle row:
 $D_{\vartheta 05} = \vartheta_A + D_{\vartheta 05} = 30 + 18.62 = 48.62^\circ C$
- for devices placed in the lower rows:
 $\vartheta < 48.62^\circ C$

TECHNICAL CHARACTERISTICS

44 CEP - BOARDS IN GW PLAST[®] 120

TECHNICAL CHARACTERISTICS

Standards: EN 60439-1; EN 62208; CEI 23-48; CEI 23-49
 Protection class: IP 55
 Indirect contact protection: double insulation - □^(*)
 Installation temperature: Max +60°C; Min -25°C
 Maximum nominal operating voltage: 690V

Material: GW PLAST 120
 Impact resistance: IK 08
 Abnormal heat and fire resistance: Thermo-pressure with ball 120°C
 Glow wire test 650°C

(*) Complete insulation to EN 61140 Standard, obtainable with screwcaps or fixing brackets GW 44 621 or GW 46 446 or GW 46 451.

BEHAVIOUR WITH CHEMICAL AND ATMOSPHERIC AGENTS

Saline solution	Acids		Bases		Solvents				Mineral oil	UV Rays
	Concentrated	Diluted	Concentrated	Diluted	Hexane	Benzol	Acetone	Ethyl alcohol		
Resistant	Limited resistance	Limited resistance	Limited resistance	Limited resistance	Limited resistance	Not resistant	Not resistant	Limited resistance	Limited resistance	Limited resistance

DIMENSION TABLES

BOARDS

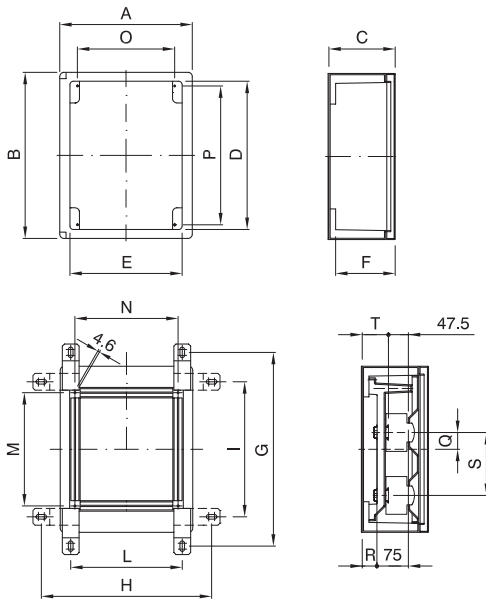

BOARDS CODE	GW 44 808 GW 44 818	GW 44 809 GW 44 819	GW 44 810 GW 44 820	GW 44 811 GW 44 821
A	200	236	316	396
B	254	316	396	474
C	135	135	160	160
D	211.5	273.5	353.5	431.5
E	151.5	187.5	267.5	347.5
F	127.5	127.5	140	140
G	321	383	463	541
H	290	326	406	486
I	181	243	323	401
L	150	186	266	346
M	129	191	271	349
N	130	166	246	326
O	116	152	232	312
P	189	251	331	409
Q	-	40	40	75
R	-	27	35	35
S	-	150	150	150
T	-	54.5	62.5	62.5

BACK-MOUNTING PLATES

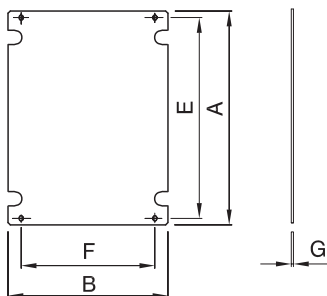

PLATE	A	B	E	F	G	DISTRIBUTION BOARD
GW 44 636					1.5	GW 44 808
GW 44 646	205.5	145.5	189	118	4	GW 44 818
GW 44 637					1.5	GW 44 809
GW 44 647	267.5	181.5	251	152	4	GW 44 819
GW 44 638					2	GW 44 810
GW 44 648	347.5	261.5	331	232	4	GW 44 820
GW 44 639					2	GW 44 811
GW 44 649	425.5	341.5	409	312	4	GW 44 821

TECHNICAL CHARACTERISTICS

46 QP - BOARDS IN POLYESTER

TECHNICAL CHARACTERISTICS

Standards: EN 60439-1; CEI EN 62208; CEI 23-48; CEI 23-49

Protection class: IP 65

Indirect contact protection: double insulation - □ (●)

Installation temperature: Max +60°C; Min -25°C

Maximum nominal operating voltage: 690V

Material: fibreglass-reinforced polyester

Impact resistance: IK 10

Abnormal heat and fire resistance: Thermo-pressure with ball 200°C

Glow wire test 960°C blank door versions

Glow wire test 650°C transparent door versions

(●) Total insulation in compliance with EN 61140 Standard, ensured by GW 46 451 and GW 46 446 brackets.

BEHAVIOUR WITH CHEMICAL AND ATMOSPHERIC AGENTS

Saline solution	Acids		Bases		Solvents				Mineral oil	UV Rays
	Concentrated	Diluted	Concentrated	Diluted	Hexane	Benzol	Acetone	Ethyl alcohol		
Resistant	Limited resistance	Limited resistance	Limited resistance	Limited resistance	Limited resistance	Limited resistance	Not resistant	Limited resistance	Resistant	Resistant

DIMENSION TABLES

BOARDS

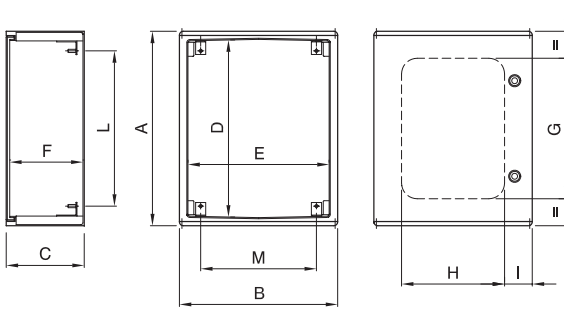

Adjustment and fixing centers for watertight boards in polyester

BOARDS CODE	GW 46 001 GW 46 201	GW 46 002 GW 46 202	GW 46 003 GW 46 203	GW 46 004 GW 46 204	GW 46 005 GW 46 205	GW 46 006 GW 46 206	GW 46 007 GW 46 207
A	300	424	499	649	649	799	1060
B	250	313	406	406	514	586	777
C	160	160	200	200	250	300	350
D	251	375	450	600	600	750	1000
E	206	269	362	362	470	542	722
F	154	154	194	194	244	294	342
G	205	310	360	510	510	650	827
H	140	169	264	264	380	440	577
I	71	71	71	71	71	71	100
L	203	327	402	552	552	702	952
M	141	202	297	297	405	477	657

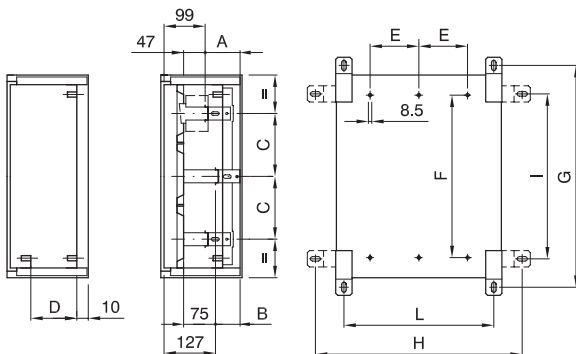

BOARDS CODE	GW 46 001 GW 46 201	GW 46 002 GW 46 202	GW 46 003 GW 46 203	GW 46 004 GW 46 204	GW 46 005 GW 46 205	GW 46 006 GW 46 206	GW 46 007 GW 46 207
A	-	55	95	95	145	195	245
B	-	27	67	67	117	167	217
C	-	125	150	150	150	150	200
D	85	85	125	125	175	225	275
E	53	84.5	131	131	184	221	307
F	185	309	384	534	470	620	860
G	348	472	547	697	695	845	1088
H	311	374	467	467	573	643	819
I	208	332	407	557	557	705	948
L	171	234	327	327	433	507	679

DISTANCES BETWEEN DOOR, INNER DOOR, BACK-MOUNTING PLATE AND PANEL

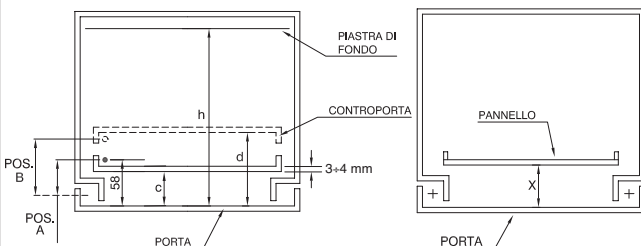

BOARD DIMENSIONS (mm)	Position A		Position B		x min.	x max
	c	h	d	h		
310 x 425	32	142	93	142	32	32
405 x 500	32	182	61	182	32	47
405 x 650	32	182	61	182	32	47
515 x 650	32	231	61	231	32	47
585 x 800	32	282	79	282	32	47
800 x 1060	43	327	99	327	41	192

TECHNICAL CHARACTERISTICS

46 QM - BOARDS IN METAL

TECHNICAL CHARACTERISTICS

Standards: EN 60439-1; CEI EN 62208; CEI 23-48; CEI 23-49

Protection class: IP 55

Indirect contact protection:
metal sheath with earth terminal

Maximum nominal operating voltage: 690V

Material: sheet metal with epoxy-polyester powder coating

Impact resistance: IK 10

Installation temperature: Max +60°C; Min -25°C

BEHAVIOUR WITH CHEMICAL AND ATMOSPHERIC AGENTS

Saline solution	Acids		Bases		Solvents				Mineral oil	UV Rays
	Concentrated	Diluted	Concentrated	Diluted	Hexane	Benzol	Acetone	Ethyl alcohol		
Limited resistance	Limited resistance	Limited resistance	Not resistant	Not resistant	Resistant	Limited resistance	Not resistant	Resistant	Resistant	Resistant

DIMENSION TABLES

BOARDS

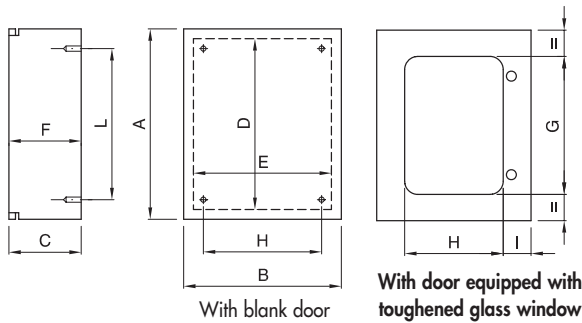

Adjustment and fixing centers for watertight boards in metal

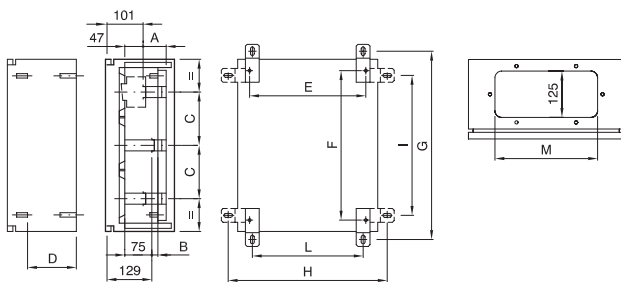

BOARDS CODE	GW 46 031	GW 46 032	GW 46 033	GW 46 034	GW 46 035	GW 46 036	GW 46 037
A	296	420	495	645	645	795	1045
B	246	309	402	402	510	582	762
C	160	160	200	200	250	300	350
D	256	380	455	605	605	755	1005
E	206	269	362	362	470	542	722
F	157	157	197	197	247	297	347
G	205	310	360	510	510	650	827
H	140	169	264	264	380	440	577
I	71	71	71	71	71	71	100
L	203	327	402	552	552	702	952
M	141	202	297	297	405	477	657

BOARDS CODE	GW 46 031	GW 46 032	GW 46 033	GW 46 034	GW 46 035	GW 46 036	GW 46 037
A	-	55	95	95	145	195	245
B	-	27	67	67	117	167	217
C	-	125	150	150	150	150	200
D	65	65	65	65	200	250	300
E	191	254	347	347	453	527	699
F	228	352	427	577	577	725	968
G	348	472	547	697	695	845	1088
H	311	374	467	467	573	643	819
I	208	332	407	557	557	705	948
L	171	234	327	327	433	507	679
M	-	-	-	270	270	335	335

DISTANCES BETWEEN DOOR, INNER DOOR, BACK-MOUNTING PLATE AND PANEL

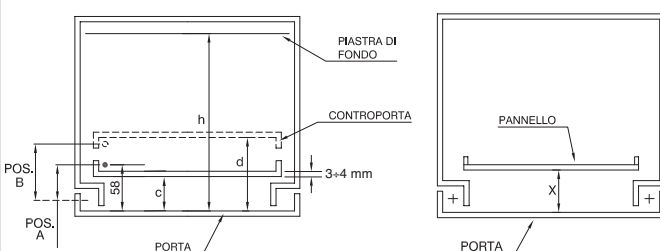

BOARD DIMENSIONS (mm)	c	d	h	x min.	x max
310 x 425	34	51	156	32	32
405 x 500	34	51	196	32	47
405 x 650	34	51	196	32	47
515 x 650	34	51	245	32	47
585 x 800	34	51	295	32	47
800 x 1060	45	73	341	41	192

TECHNICAL CHARACTERISTICS

46 QX - BOARD IN STAINLESS STEEL

TECHNICAL CHARACTERISTICS

Standards: EN 60439-1; CEI EN 62208; CEI 23-48; CEI 23-49

Protection class: IP 55

Indirect contact protection:
metal sheath with earth terminal

Material: AISI 304 type stainless steel

Impact resistance: IK 10

Installation temperature: Max +60°C; Min -25°C

Maximum nominal operating voltage: 690V

BEHAVIOUR WITH CHEMICAL AND ATMOSPHERIC AGENTS

Saline solution	Acids		Bases		Solvents				Mineral oil	UV Rays
	Concentrated	Diluted	Concentrated	Diluted	Hexane	Benzol	Acetone	Ethyl alcohol		
Limited resistance	Not resistant	Limited resistance	Limited resistance	Limited resistance	Resistant	Resistant	Resistant	Resistant	Resistant	Resistant

DIMENSION TABLES

BOARDS

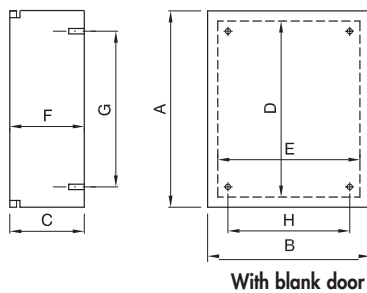

BOARDS CODE	GW 46 052	GW 46 054	GW 46 056
A	420	645	795
B	309	402	582
C	160	200	300
D	380	605	755
E	269	362	542
F	157	197	297
G	327	552	702
H	202	297	477

Adjustments and fixing centres for watertight boards in satin-finish stainless steel

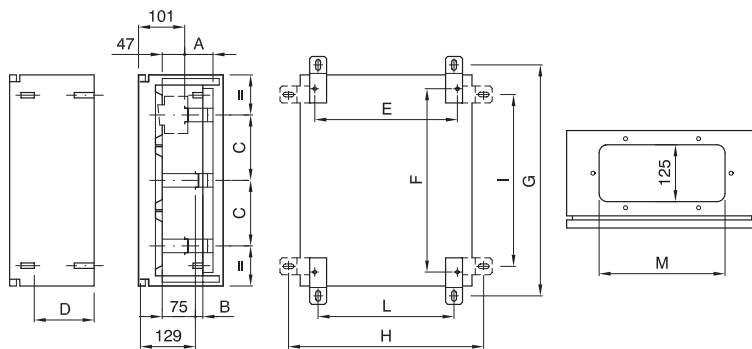

BOARDS CODE	GW 46 052	GW 46 054	GW 46 056
A	55	95	195
B	27	67	167
C	125	150	150
D	65	65	250
E	254	347	527
F	352	577	725
G	472	697	845
H	374	467	643
I	332	557	705
L	234	327	507
M	-	270	335

DISTANCES BETWEEN DOOR, INNER DOOR, BACK-MOUNTING PLATE AND PANEL

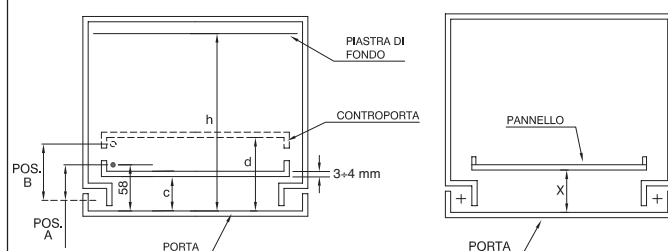

BOARD DIMENSIONS (mm)	c	d	h	x min.	x max
310 x 425	34	51	156	32	32
405 x 500	34	51	196	32	47
405 x 650	34	51	196	32	47
515 x 650	34	51	245	32	47
585 x 800	34	51	295	32	47
800 x 1060	45	73	341	41	192

46 QP - QM - QX - COMMON COMPLEMENTARY ITEMS

DIMENSION TABLES

FRONT CONFIGURATION

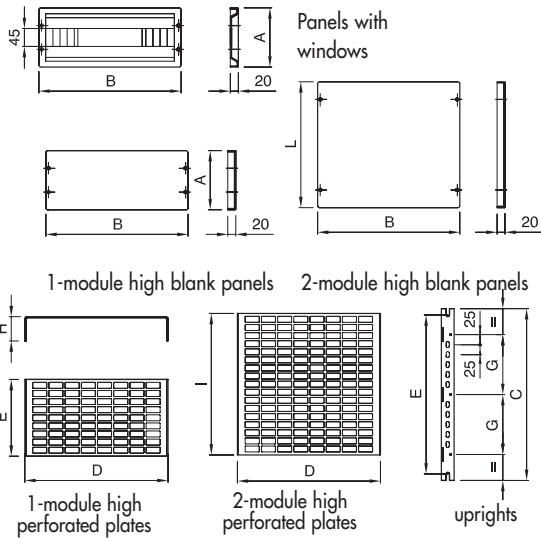

PANELS WITH WINDOW	-	GW 46 420	GW 46 421	GW 46 421	GW 46 422	GW 46 423	GW 46 424	
SINGLE BLANK PANELS	-	GW 46 425	GW 46 426	GW 46 426	GW 46 427	GW 46 428	GW 46 429	
DOUBLE BLANK PANELS	-	GW 46 475	GW 46 476	GW 46 476	GW 46 477	GW 46 478	GW 46 479	
UPRIGHTS	-	GW 46 435	GW 46 436	GW 46 437	GW 46 437	GW 46 438	GW 46 439	
SINGLE PERFORATED PLATES	-	GW 46 440	GW 46 441	GW 46 441	GW 46 442	GW 46 443	GW 46 444	
DOUBLE PERFORATED PLATES	-	GW 46 480	GW 46 481	GW 46 481	GW 46 482	GW 46 483	GW 46 484	
FOR BOARD DIMENSIONS (mm)		300 x 250	425 x 310	500 x 405	650 x 405	650 x 515	800 x 585	1060 x 800
NUMBER MODULES	-	12	18	18	24	28	36	
A	-	124	149	149	149	149	199	
B	-	265	358	358	466	538	718	
C	-	355	430	580	580	730	980	
D	-	170	265	265	373	445	625	
E	-	116	142	142	142	142	190	
F	-	327	402	552	552	702	952	
G	-	125	150	150	150	150	200	
H	-	40	45	45	45	45	45	
I	-	241	292	292	292	292	390	
L	-	249	299	299	299	299	399	

INTERNAL CONFIGURATION

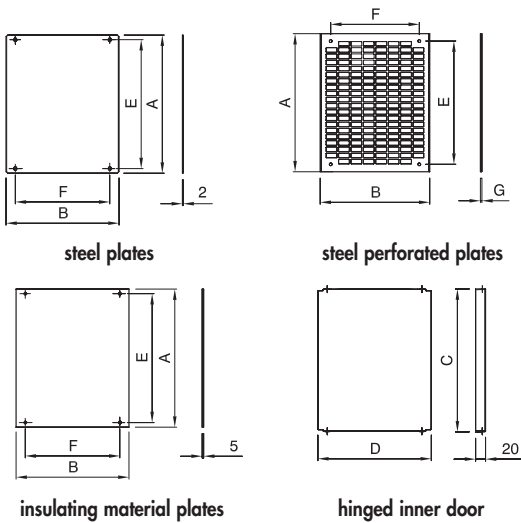

STEEL PLATES	GW 46 401	GW 46 402	GW 46 403	GW 46 404	GW 46 405	GW 46 406	GW 46 407	
PERFORATED PLATES	GW 46 461	GW 46 462	GW 46 463	GW 46 464	GW 46 465	GW 46 466	GW 46 467	
INSULATED PLATES	GW 46 408	GW 46 409	GW 46 410	GW 46 411	GW 46 412	GW 46 413	-	
INTERNAL DOOR	-	GW 46 414	GW 46 415	GW 46 416	GW 46 417	GW 46 418	GW 46 419	
FOR BOARD OF DIMENSIONS (mm)		300 x 250	425 x 310	500 x 405	650 x 405	650 x 515	800 x 585	1060 x 800
A	235	359	434	584	584	734	984	
B	199	260	355	355	463	535	715	
C	-	370	445	595	595	745	995	
D	-	264	357	357	465	537	712	
E	203	327	402	552	552	702	952	
F	141	202	297	297	405	477	657	
G	1.5	2	2	2	2	2	2	

COMPLEMENTARY ITEMS

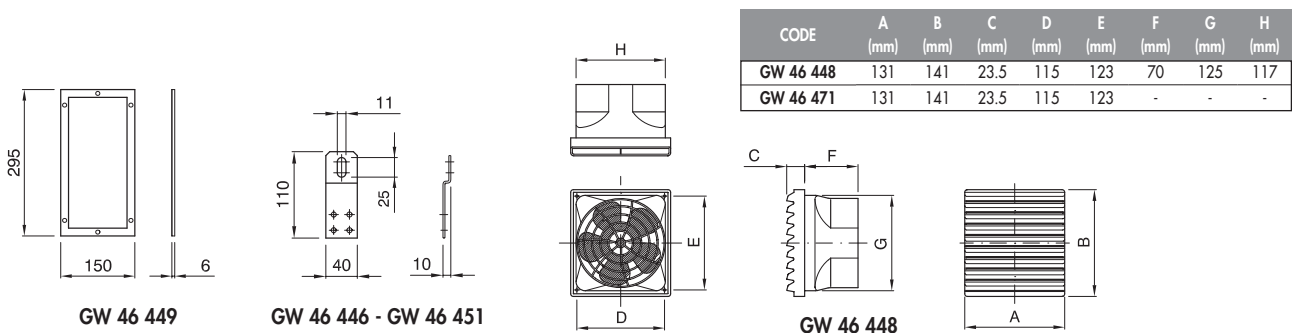

CERTIFICATION CRITERIA FOR DISTRIBUTION AND CONTROL BOARDS FOR RESIDENTIAL AND SIMILAR USES (CEI 23-51 STANDARD)

A APPLICATION CONDITIONS

The CEI 23-51 Standard allows the installer to certify boards and control units created by installing control, command, protection, measurement and signalling devices into envelopes prefabricated under the following conditions:

- ① the envelopes must have been declared as compliant with the CEI 23-49 Standard by the manufacturer and the maximum dissipated power P_{inv} must be known;
- ② the use must be envisaged for environments with temperature not higher than 25°C which can occasionally reach 35°C;
- ③ voltage cannot be higher than 440V;
- ④ the nominal input current of the board (see point C) must not be higher than 125A;
- ⑤ the presumed short-circuit current at the point of installation must not be higher than 10 kA or the boards must be protected by current limiting devices with limited current not higher than 15 kA.

Thermal checks are not necessary for single-phase boards with INQ lower than 32A.

B VALUATION OF TOTAL POWER PTOT DISSIPATED BY DEVICES

In order to carry out the calculation, the following elements must be known:

- ① operating currents of output circuits I_{nu} ; if these are not known, they can be calculated using appropriate contemporaneity factors;
- ② the distribution scheme with respect to the number of active poles for each circuit (the active pole is that one that produces heat in the respective pole of the device);
- ③ the power dissipated at nominal current (P_n) by each of the devices installed in the board (supplied by the manufacturer of the device);
- ④ the nominal current I_n of each device (obviously $I_n \geq I_{nu}$ and, for automatic circuit breakers, $I_n \leq I_z$ also applies, where I_z is the load of the conduit to be protected).

The operating current I_{nu0} of the main switch is established by the Standard as conventionally equal to 0.85 I_{no} (except better conditions determined by the designer when the contemporaneity factor is low). The calculation of the effected power dissipated by each device can be effected using the formula:

$$P_i = n P_n \left(\frac{I_{nu}^2}{I_n^2} \right) \text{ where } n \text{ is the number of active poles}$$

The total power dissipated by the devices P_{dp} is the sum of the single powers ($P_{dp} = P_1 + P_2 + P_3$ etc.).

The power dissipated by connections is conventionally estimated at 20% of P_{dp} . The total dissipated power P_{TOT} is given by $P_{TOT} = P_{dp} + 0.2 P_{dp}$ (see the numeric example below).

Note: the power dissipated by modular GEWISS devices is indicated in the EURO DIN catalogue.

EXAMPLE OF CALCULATION OF DISSIPATED POWER FOR THE CONTROL UNIT

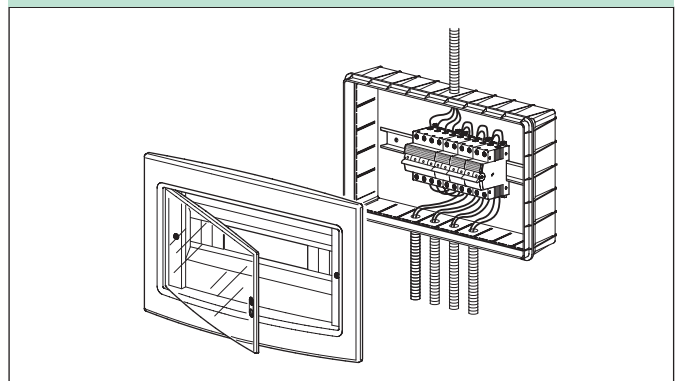

ELECTRICAL WIRING

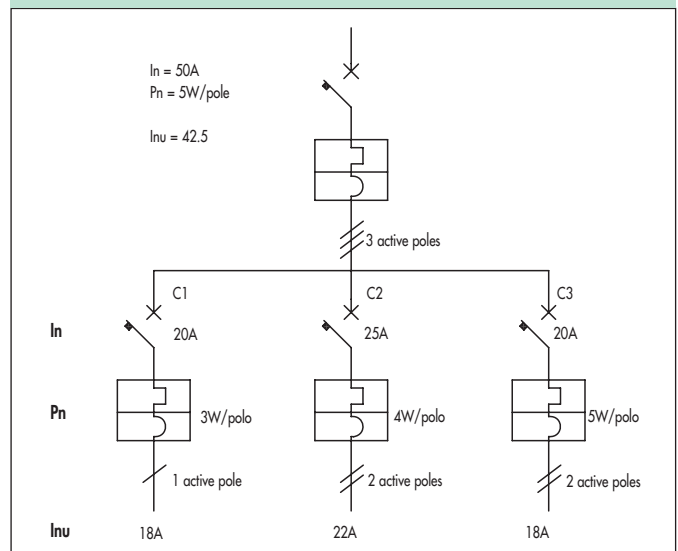

NUMERIC CALCULATION EXAMPLE

Circuit	No. active poles	P_n (W)	I_{nu}	I_n	I_{nu}^2 / I_n^2	P (single) (W)
0	3	5	42.5	50	0.722	11.58
1	1	3	18	20	0.810	2.43
2	2	4	22	25	0.774	6.19
3	2	3	18	20	0.810	4.86
P_{dp} (W)						25.06
Power dissipated by connections and small devices (relay, timer, etc.) 20% P_{dp}						5.01
Total dissipated power P_{TOT} (W)						30.07

C VALUATION OF NOMINAL CURRENT OF THE DISTRIBUTION OR CONTROL UNIT

In order to evaluate the nominal current for the distribution board, it is necessary to first evaluate the input nominal current (I_{ne}) and the output nominal current (I_{nu}).

The nominal current I_{ne} is given by the sum of the nominal currents of all protection and control devices installed on the input circuits (normally just one, i.e. the main switch) multiplied the conventional factor of 0.85.

The nominal output current I_{nu} is the sum of the nominal currents of all protection and control devices installed on the output circuits.

In the valuation of I_{ne} and I_{nu} the devices which are not designed to be in operation at the same time are not considered (for instance: ordinary lighting and emergency lighting).

The board's nominal current (I_{nq}) is the lowest value between I_{ne} and I_{nu} (see the numeric example shown).

EXAMPLE OF CALCULATION OF NOMINAL CURRENT FOR THE CONTROL UNIT

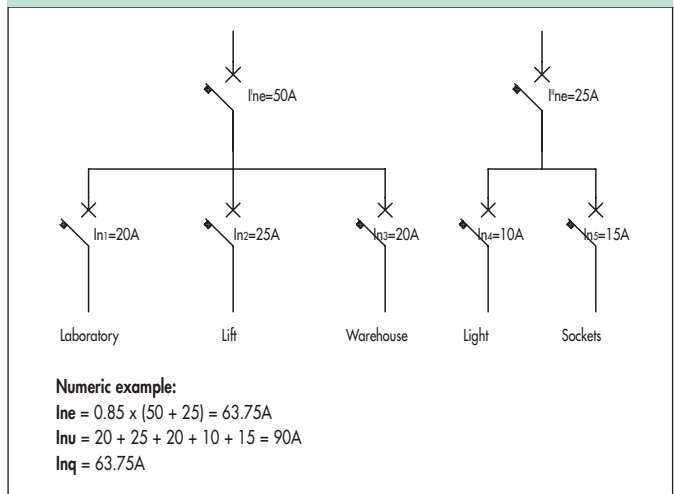

D CHOICE OF ENVELOPE AND DECLARATION OF CONFORMITY FOR THE BOARD

The suitable envelope is the one having maximum available power (as declared by the manufacturer) not lower than the maximum power dissipated by the devices calculated as at described in point B.

It is necessary to write a verification report consisting of a table showing the calculations and the main data of the type described below.

Note: the maximum power that can be dissipated by GEWISS boards and enclosures is shown in this catalogue for the relevant ranges.

Power dissipated by protection and control devices

Type of circuit	No. current	Pn W / pole	No. poles	Pd (W)	K	P per device (W)
Input						
In output						

FACSIMILE of conformity declaration to be written on headed paper.

Rossi Mario & C. s.n.c.
Impianti elettrici
 Via Cerruti, 26 - 20150 MILANO

Declaration of conformity

We hereby declare that the distribution board type installed at..... as per enclosed diagram and characterised by following nominal data:

Nominal voltage Un: **400V**
 Nominal current: **63A3~ 50 Hz**
 Protection class: **IP 55**

is conformant to the CEI 23-51 Standard "Guidelines for checks and tests for distribution boards for residential use or similar."

Place and date Signature of the legal representative

GWTEST: QUOTING AND THERMAL CHECK FOR BT BOARDS TO CEI 23-51 STANDARD



GWTEST software

The GWTEST software is a key tool which facilitates and speeds up verification of conformity to the CEI 23-51 Standard for distribution boards.

It allows the user to check overtemperature limits, with relevant printout of the conformity declaration and, at the same time, enables the drafting of quotes.

Minimum installation requirements

Computer: Pentium 100 MHz or higher - RAM: 32 Mb - Operating system: Windows 95 or higher version

Main functional characteristics

- Calculation of nominal current of the distribution board I_{nq}
- Calculation of nominal power dissipated within the board
- Check of the $P_{tot} \leq P_{inv}$ relationship, i.e. of the fact that the power dissipated by the devices is lower than or equal to the maximum power that can be dissipated by the envelope
- Printout of component list (circuit breakers and auxiliary devices)
- Printout of the report on verification of overtemperature limits
- Printout of declaration of conformity to a good standard of workmanship
- Quote calculation and printing